

CHECK VALVE



STAINLESS STEEL SWING CHECK VALVE SCREWED ENDS

FEATURE AND APPLICATION

- Inspection & test acc. to API 598, EN 12266-1
- Precision, high quality investment castings
- Screwed-in cover; integral stainless steel seat
- Swing type disc
- Applicable Medium : Water, Oil, Gas , Acid
- Screwed end BSPT Connection
- Max.Working Pressure : 200 PSI (14 Bar)
- Max.Working Temperature : -20 °C To 180 °C
- Size Range : 1/2" - 3"

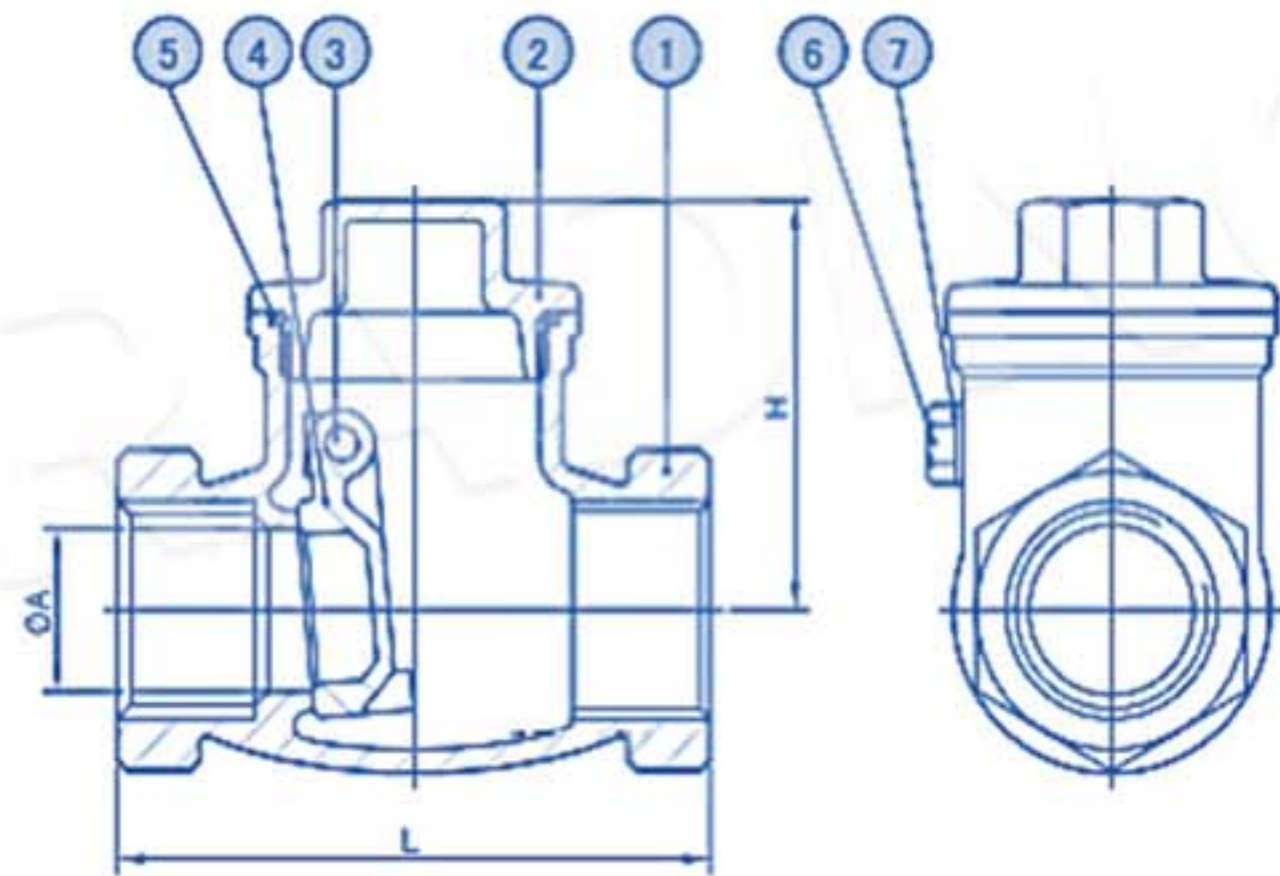

Bill of Materials

| Seqeybce | Description | Material | Sizes |
|----------|----------------|----------|-------|
| 1 | Body | SUS 316 | All |
| 2 | Cap | SUS 316 | All |
| 3 | Hanger Pin | SUS 316 | All |
| 4 | Disc | SUS 316 | All |
| 5 | Gasket Packing | PTFE | All |
| 6 | Plug | SUS 316 | All |
| 7 | Plug Packing | PTFE | All |

Dimensions

mm

| DN | INCH | A | H | L |
|----|--------|----|-----|-----|
| 15 | 1/2" | 15 | 45 | 65 |
| 20 | 3/4" | 20 | 56 | 80 |
| 25 | 1" | 25 | 62 | 90 |
| 32 | 1-1/4" | 32 | 67 | 105 |
| 40 | 1-1/2" | 40 | 73 | 120 |
| 50 | 2" | 50 | 82 | 140 |
| 65 | 2-1/2" | 65 | 93 | 180 |
| 80 | 3" | 80 | 104 | 200 |